

HTB 1840 TTB 1840G

SCRUBBER DRYER

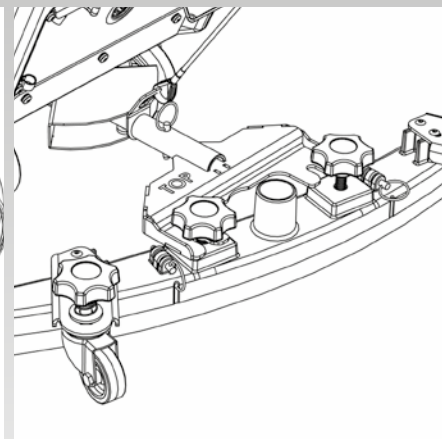
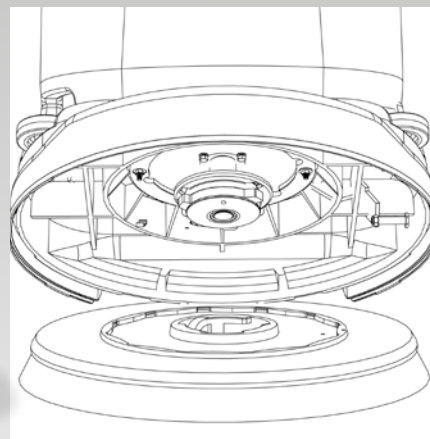

Owner Instructions

Warning! Read instructions before using the machine



SCRUBBER DRYER

HTB 1840 & TTB 1840G

Index

Machine Overview	Pages 2
Control Panel Overview	Page 3
Quick Set up Guide	Page 4
Machine Set up Guide	Page 5
Fitting the Brush / Pad	Page 5
Fitting the Floor Tool	Page 5
Filling the Clean Water Tank	Page 6
Fill Level Indicator	Page 6
Water Flow Adjustment	Page 6
Setting the Cleaning Controls	Page 7
Raising/Lowering Floor Tool	Page 8
Emptying Top/Bottom Tanks	Page 8
Machine in Use	Page 8
Regular Maintenance	Page 9
Changing Floor tool Blades	Page 10
Removing Battery	Page 11
Removing Battery Fuse	Page 11
Battery Charging	Page 11
HTB1840 Face Fitting	Page 12-13
Specifications	Page 14
Trouble Shooting	Page 14
Rating Label / Personal Protective Equipment / Recycling	Page 15
Safety Precautions	Page 16-17
Recommended Spare Parts	Page 18
Schematic Diagram	Page 18
EU Declaration Document	Page 19
Warranty	Page 20
Company Address	Page 23

PLEASE READ BEFORE COMMENCING OPERATION

After the removal of all the packaging,
carefully open and check the contents

- Owner Manual
- Battery Charger & Lead
- Battery Pack • Scrub Brush
- Squeegee Assembly

1	Operator control panel (see page 3)
2	Triggers
3	Waste-water tank
4	Clean-water tank
5	Brush deck
6	Squeegee blades
7	Floor-tool retaining knobs
8	Clean-water On / Off tap
9	Clean-water emptying cap
10	Floor-tool vacuum hose
11	Vacuum hose
12	Separator
13	Clean-water filler cap
14	Clean-water level indicator
15	Clean-water tank fill point
16	On / Off switch
17	Battery connector
18	Top tank (waste water) drainage hose
19	Battery

Machine Overview

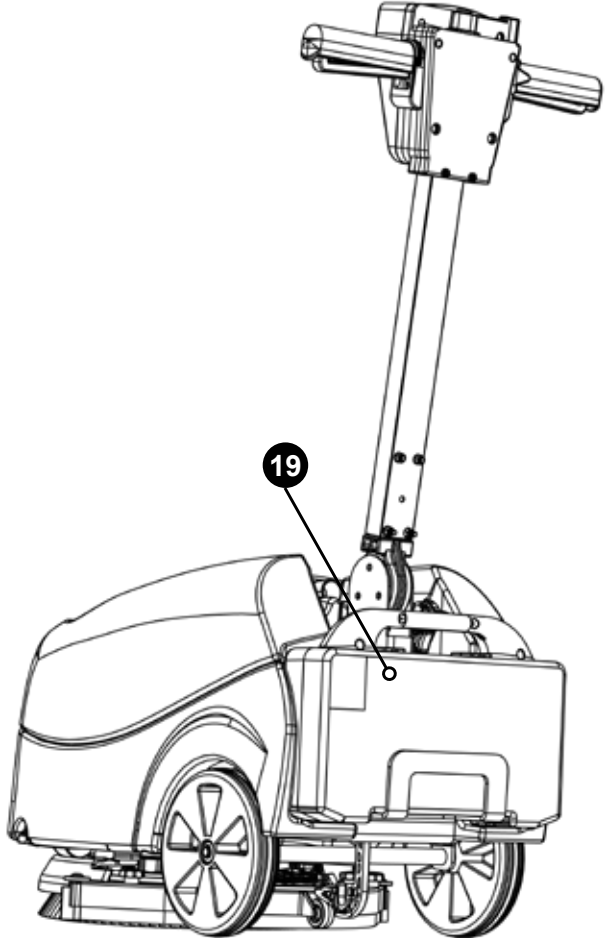
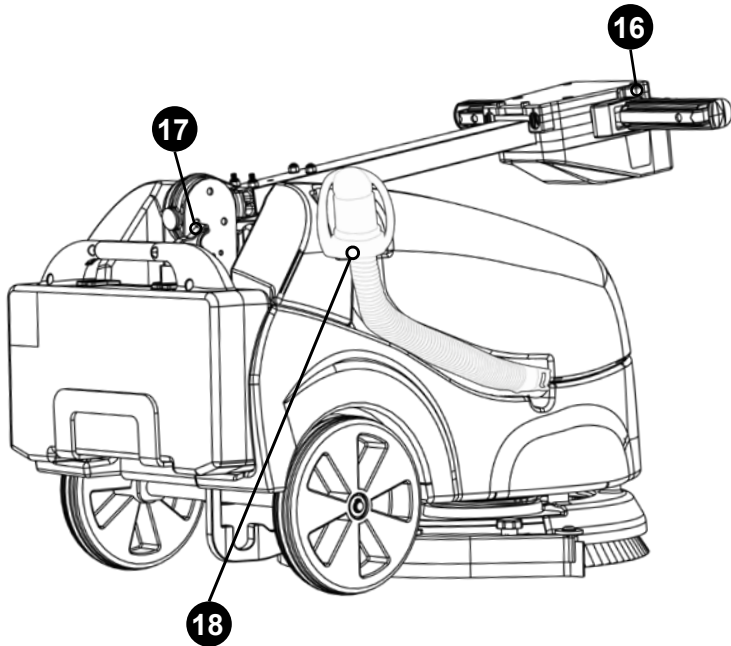
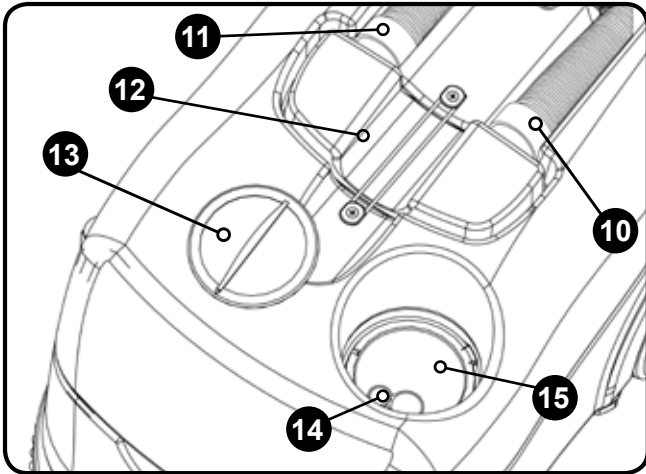
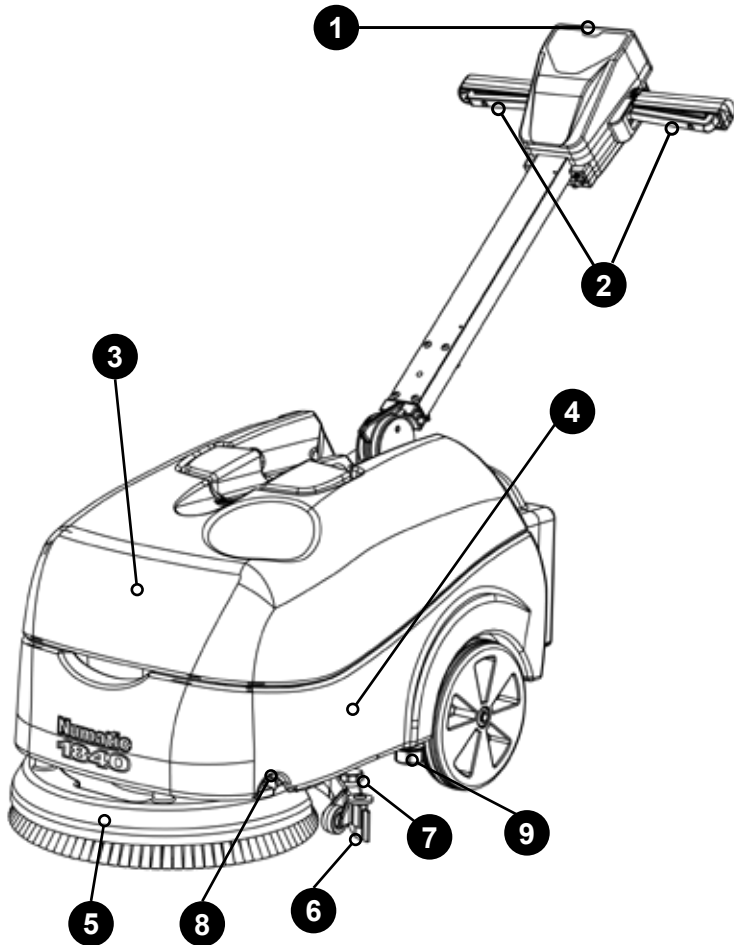

SCRUBBER DRYER

HTB 1840 & TTB 1840G

Control Panel Overview

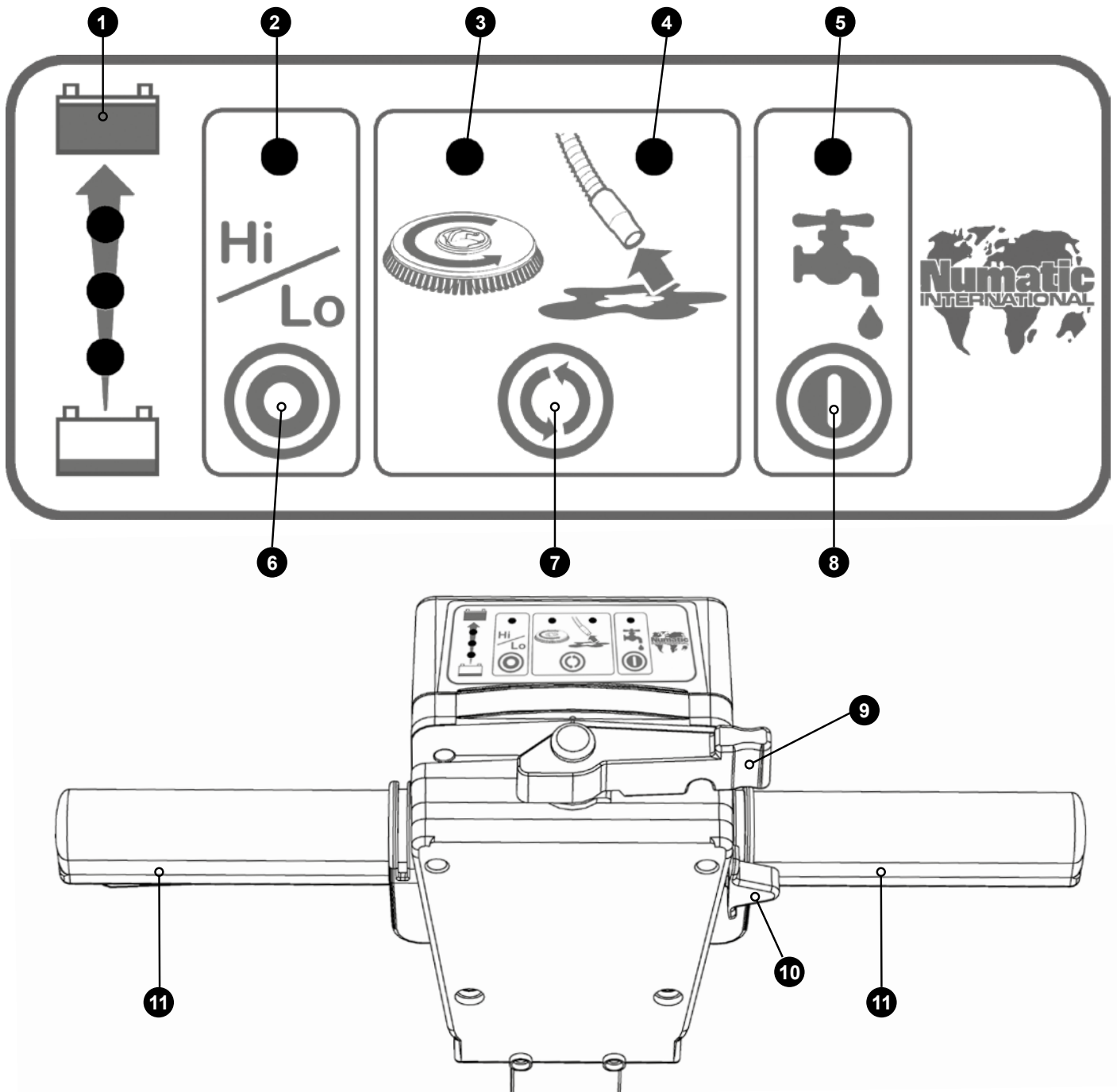

1	Battery Charge Level Meter
2	Hi / Lo Indicator
3	Brush Operation / Load Indicator
4	Vacuum Indicator
5	Water Flow Indicator
6	Hi / Lo Button
7	Mode Select Button
8	Water Flow On / Off Button
9	Handle Position Lever
10	Start Switch
11	Triggers

*In the event of a breakdown contact
your Numatic dealer or the
Numatic Technical
help line +44 (0)1460 269268*



PLEASE READ BEFORE COMMENCING ANY OPERATION. AFTER THE REMOVAL OF ALL THE PACKAGING, CAREFULLY OPEN AND CHECK THE CONTENTS.



HTB 1840 & TTB1840G CONTENTS

- Owner Manual
- Battery Charger & Lead
- Battery Pack • Scrub Brush
- Squeegee Assembly

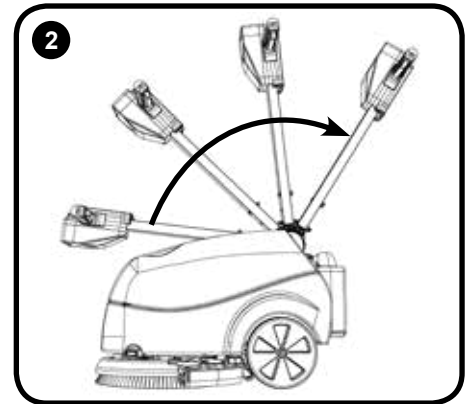
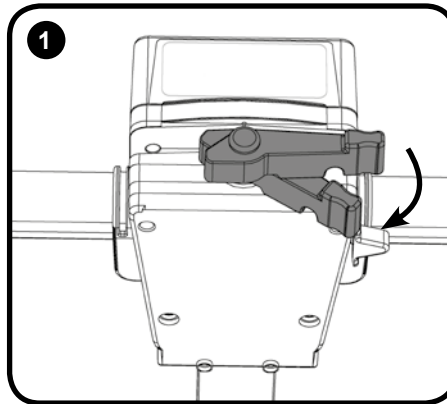

Using the handle position lever, (Fig.1) move the handle into the upright position, (Fig.2)

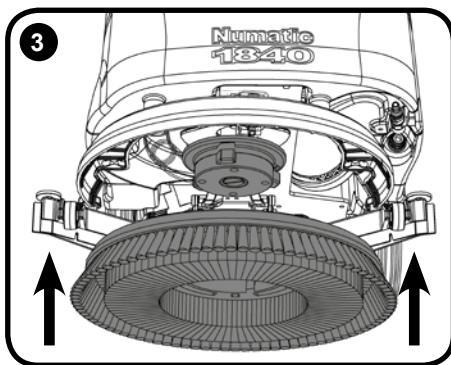

Slide the brush / pad under the brush deck (Fig.3).

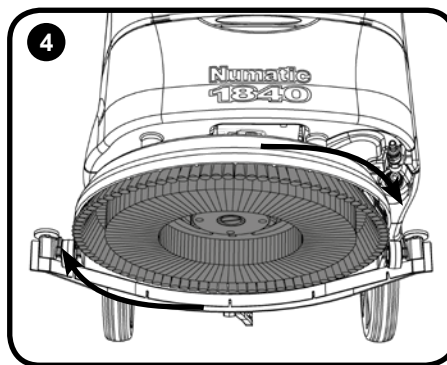

Fit the brush / pad onto the Nulock drive chuck, twist to lock the brush / pad in place (Fig.4).

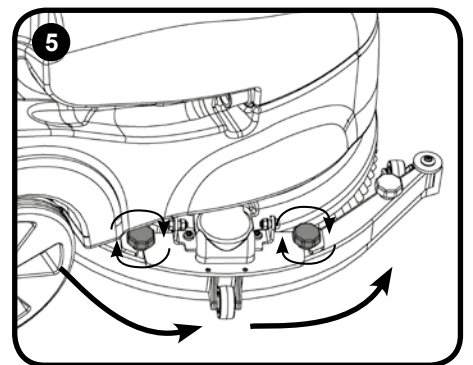

Swing the floor-tool carrier from behind the brush. Using the two locking knobs fitted to the floor-tool, secure to the floor-tool to the floor-tool carrier (Fig.5).

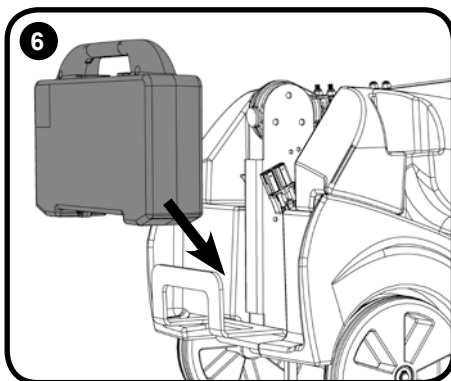

Fit the battery to the machine (Fig.6) and plug in the power supply (Fig.7). Ensure the battery has been charged before use.

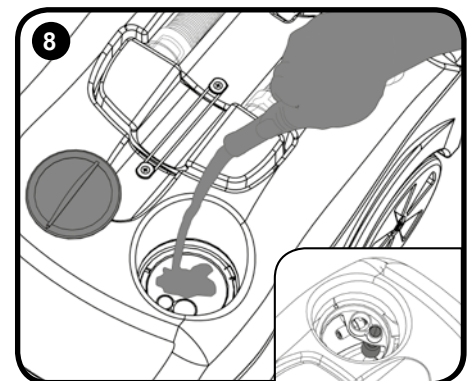
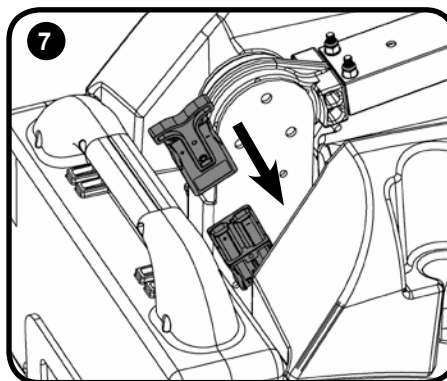

Fill the clean-water to a Max of 18 litres

Machine Set-up Guide



**ALWAYS ENSURE THAT THE MACHINE IS SWITCHED OFF
BEFORE MAKING ANY ADJUSTMENTS**



Fitting the Brush / Pad / Turn on water

400mm Brush / 360mm Pad.

Featuring the Nulock brush system.

The brush is simply pushed and twisted to lock, making fitting and removal a simple process.

Slide the brush / pad under the brush deck.

Fit the brush / pad onto the Nulock drive chuck, twist to lock the brush / pad in place.

Safety gloves are recommended for the changing of used brushes.

Turn on the clean water tap.

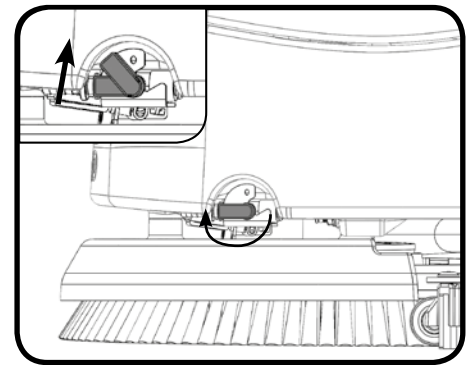
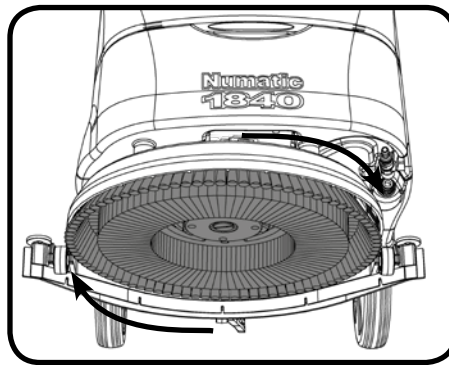
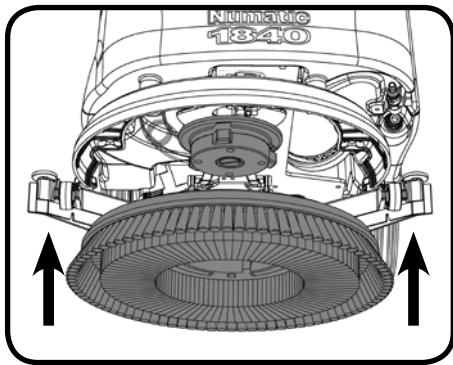

Fitting the Floor Tool

The floor tool has been designed for quick fitting, allowing easy squeegee blade replacement and a safety knock-off feature if the floor tool gets snagged, whilst in transit.

NOTE: It is easier to fit the floor tool if the weight of the machine is resting on the brush. Ensure the brush is fitted first.

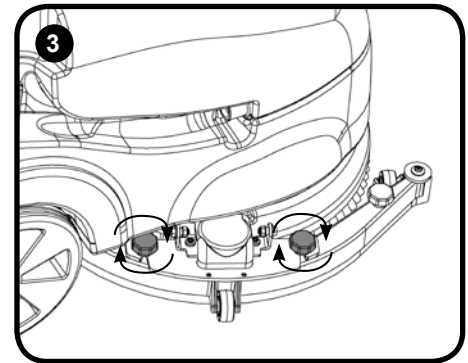
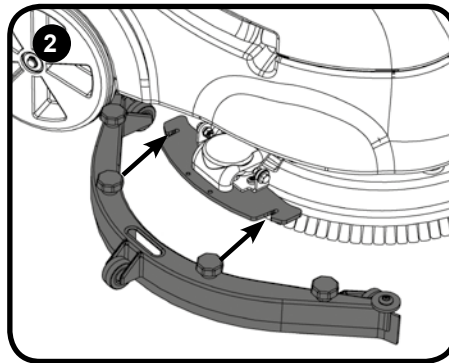
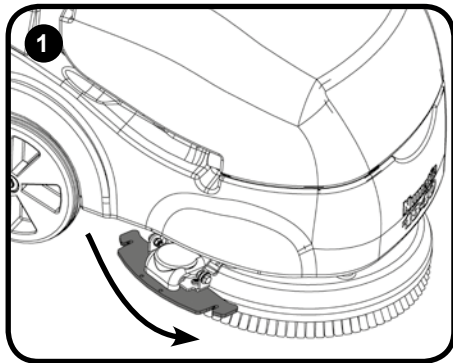

Swing the floor-tool carrier to the side of the machine. (Fig.1).

Secure to the carrier using the two knobs fitted to the floor-tool carrier (Fig.2) - (Fig.3).

Do not over tighten the retaining knobs.

Ensure inspection cap is in place on the fluid pipe. (Fig.4) - (Fig.5)

For fitting the floor tool blades
(See Page 10).

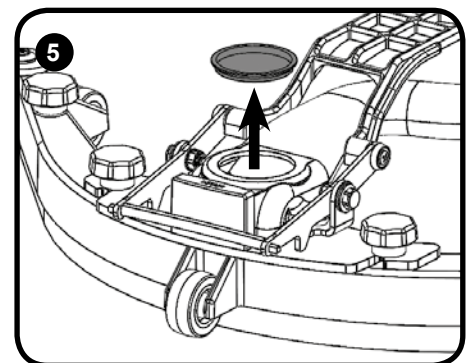
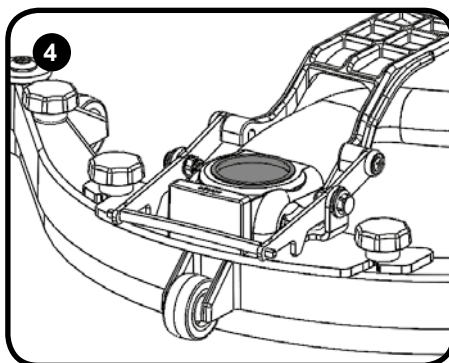

Filling the Clean Water Tank

The HTB 1840 & TTB 1840 is equipped with a large 18 litre clean-water tank allowing large areas to be cleaned in a single fill.

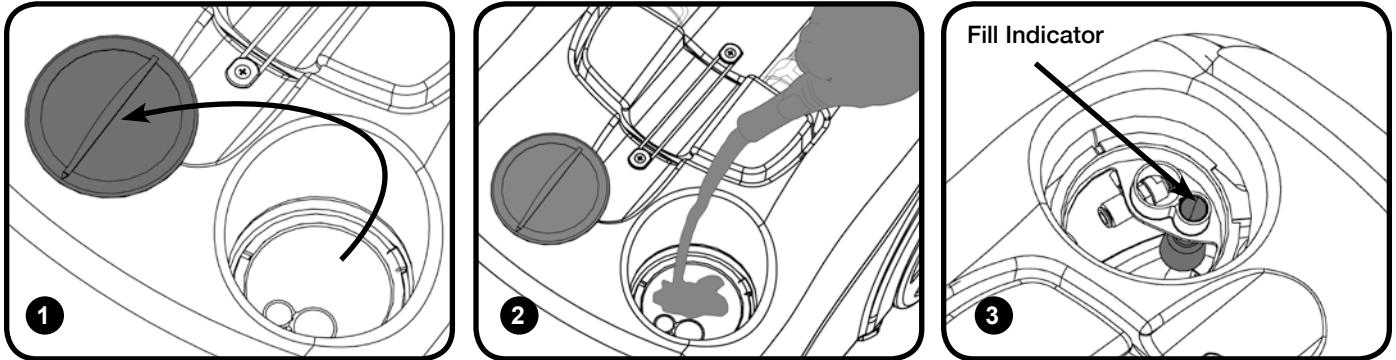

To fill the clean-water tank, remove the filler cap (Fig.1). Fill using a hose, bucket or a suitable container (Fig.2). Use the fill indicator (Fig.3).

NOTE: Great care must be taken to ensure that contaminants (leaves, hair, dirt, etc.) are not allowed to enter the clean water tank during the filling process. If using a bucket or similar, ensure it is always clean and free from debris.

Fill Level Indicator

The HTB 1840 & TTB 1840 is equipped with a large 18 litre clean-water tank allowing large areas to be cleaned in a single fill.

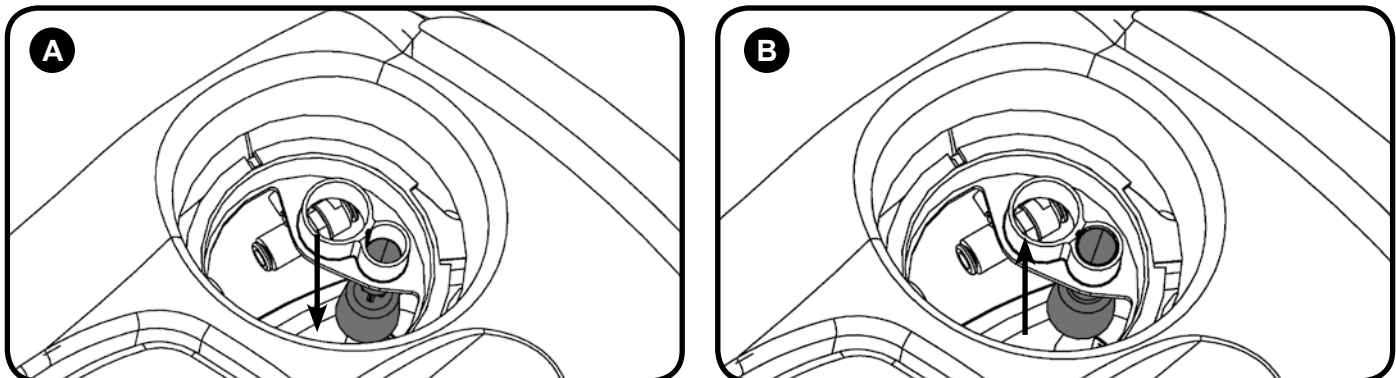

Showing the clean-water tank empty
(Fig.A)

Showing the clean-water tank full
(Fig.B)

Water Flow Adjustment

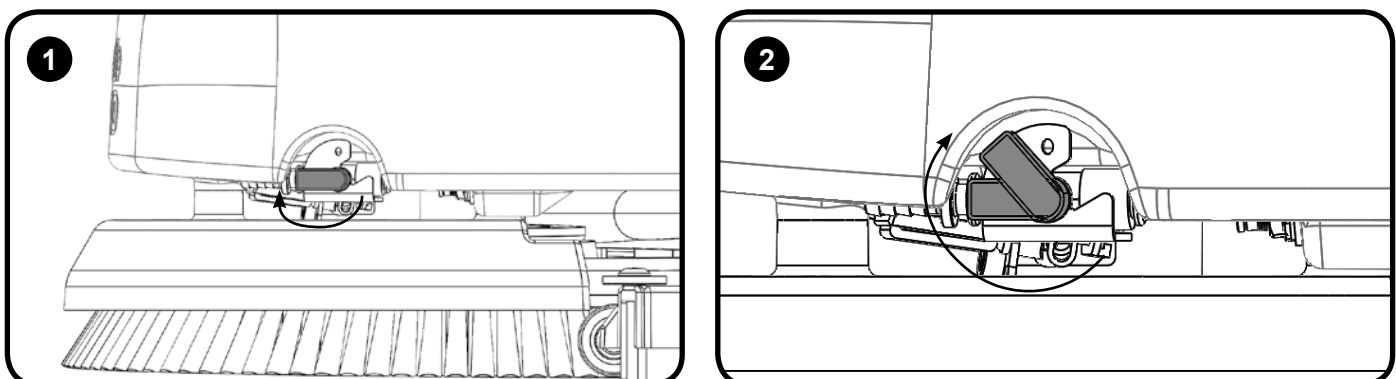

Located on the left of the machine is the On / Off water tap (Fig.1).

Ideally set the tap to 45° this enables the cleaning solution to last the same time as a fully-charged battery (Fig.2).

Setting the cleaning controls

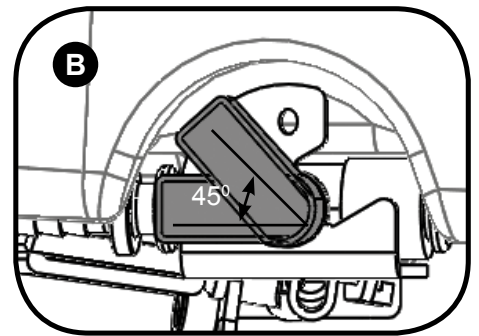
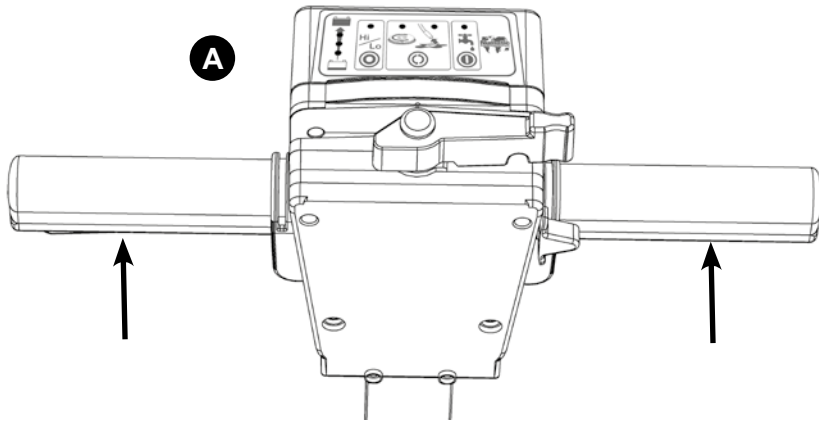

To activate the control panel: press the  Mode select button or press a trigger (Fig.A).

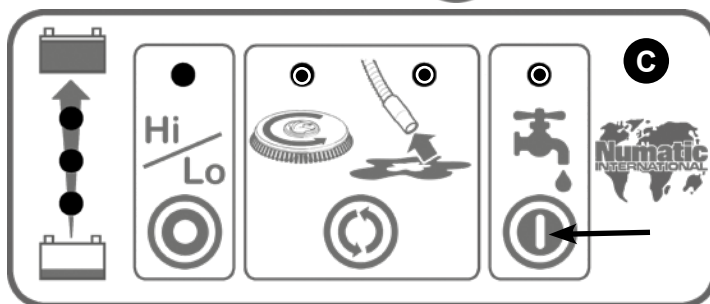

To start: hold down either Trigger and press the On / Off Switch once (Fig.A).

Whilst the brush motor is running press the water flow On / Off Button for fluid control (Fig.C), the clean water On / Off tap must be open.

Ideally set the tap to 450 (Fig.B) this enables the cleaning solution to last the same time as a fully-charged battery.

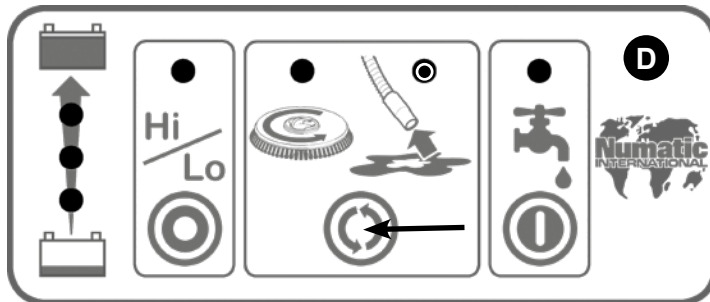

When the Triggers are released the brush motor and the cleaning solution pump will switch off, the vacuum motor will continue for 10 seconds.



Press the mode select button to operate the brush only (Fig.D).

The start sequence is required in this mode. The water flow On / Off button will operate in this mode.

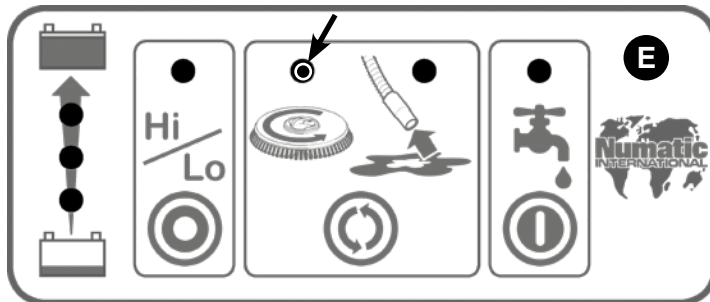

Press the mode select button again to get vacuum only. The On / Off Switch and triggers are not required in this mode. (Fig.E)

Press the mode select button to switch this mode off and return to default mode.

The panel if unused will automatically turn off after 60 seconds.

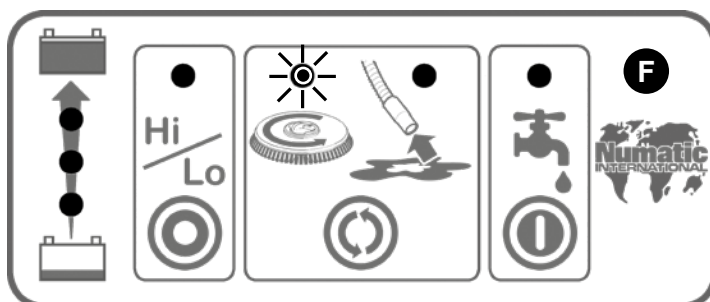

Brush Overload

The brush motor will cut out and the brush load light will flash if the brush motor has been overloaded (Fig.F).

Releasing the handle triggers will allow the machine to reset.



IMPORTANT

If the brush motor keeps overloading consider using a different type of brush. Heavy brush load decreases the available battery run time.



Raising/Lowering the Floor Tool

To raise the floor-tool, ensure the floor-tool carrier is central to the machine. Lift the lever near the base of the handle and lock into position.

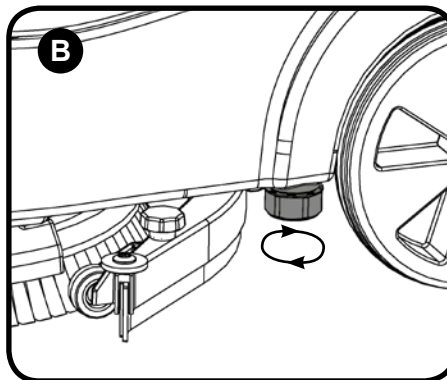
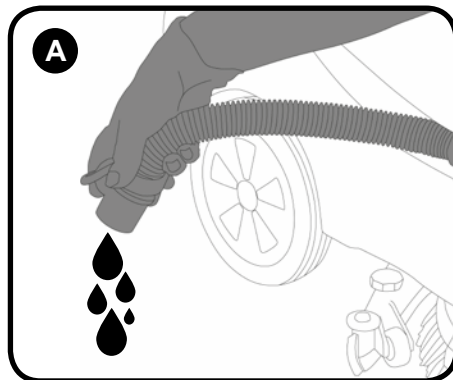
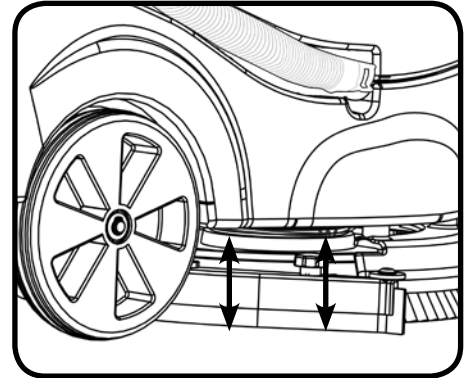
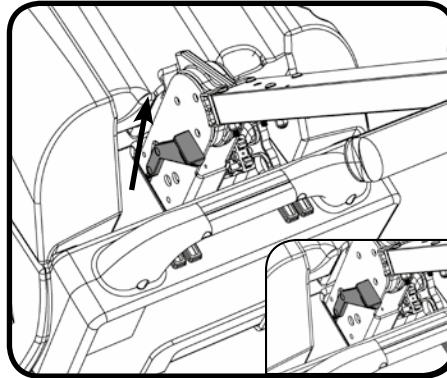

Emptying Top Tank

After use, empty waste-water tank using emptying hose and flush-out with clean water. (fig.A).

Emptying Bottom Tank

The clean-water tank can be drained via the yellow cap fitted to the left hand side of the machine. There is a sealing bung beneath the yellow cap (ensure the sealing bung is clean) The cap should only be done up by hand. (fig.B).

WHEN HANDLING AND MIXING CHEMICALS
 Always ensure that chemical manufacturer's safety guidelines are followed.
 Only use chemicals recommended for use in auto scrubber-dryers.

IMPORTANT
 Do not operate machine unless the Operator Manual has been read and fully understood.

Machine In Use

To operate, set water flow rate tap, lower the floor tool, press the vacuum / water switches, pull brush On/Off trigger.

The waste water is then retrieved by the suction floor tool. Overlap each scrubbing path by 10cm to ensure an even clean. Do not operate the machine on inclines that exceed (2%), when full.

On heavily soiled floors use a 'double scrub' technique. First pre-scrub the floor with the floor tool in the raised position, allow the chemical time to work then scrub the area a second time with the floor tool lowered.

If streaking occurs wipe floor tool blades clean.

NOTE: Care must be taken to reduce speed when cornering or when manoeuvring around obstacles

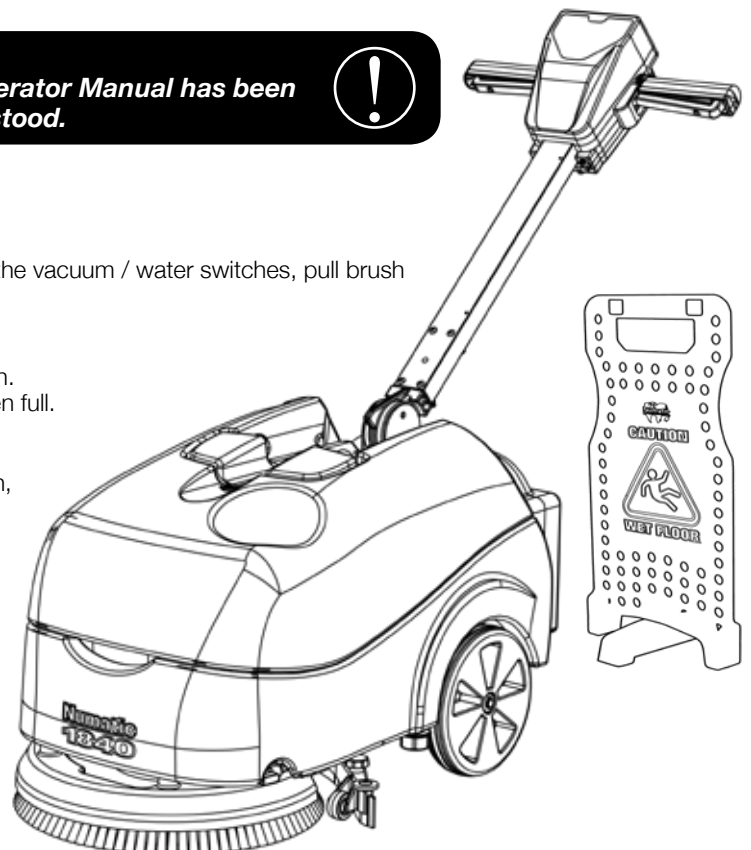

Regular Maintenance



**ALWAYS ENSURE THAT THE BATTERY IS DISCONNECTED
PRIOR TO ANY MAINTENANCE OPERATION**

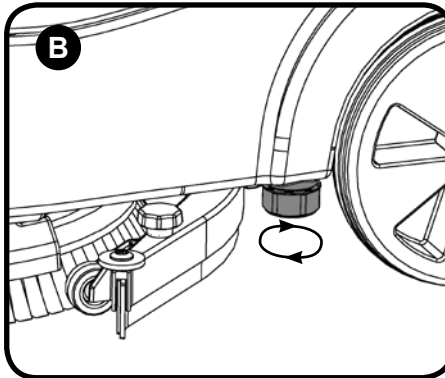
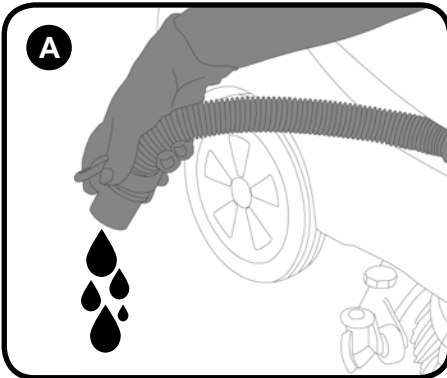

Emptying Top Tank

After use, empty waste-water tank using emptying hose and flush-out with clean water. (fig.A).

Emptying Bottom Tank

The clean-water tank can be drained via the yellow cap fitted to the left hand side of the machine. There is a sealing bung beneath the yellow cap (ensure the sealing bung is clean) The cap should only be done up by hand. (fig.B).

Separator

Remove the two hoses to disconnect the separator from the machine (Fig.1 & 2).

Remove fixing band holding separator in place (Fig.3).

Lift off the separator. The separator has a sealing-rubber which should be examined at every clean-down (Fig.4).

Rinse using clean water.

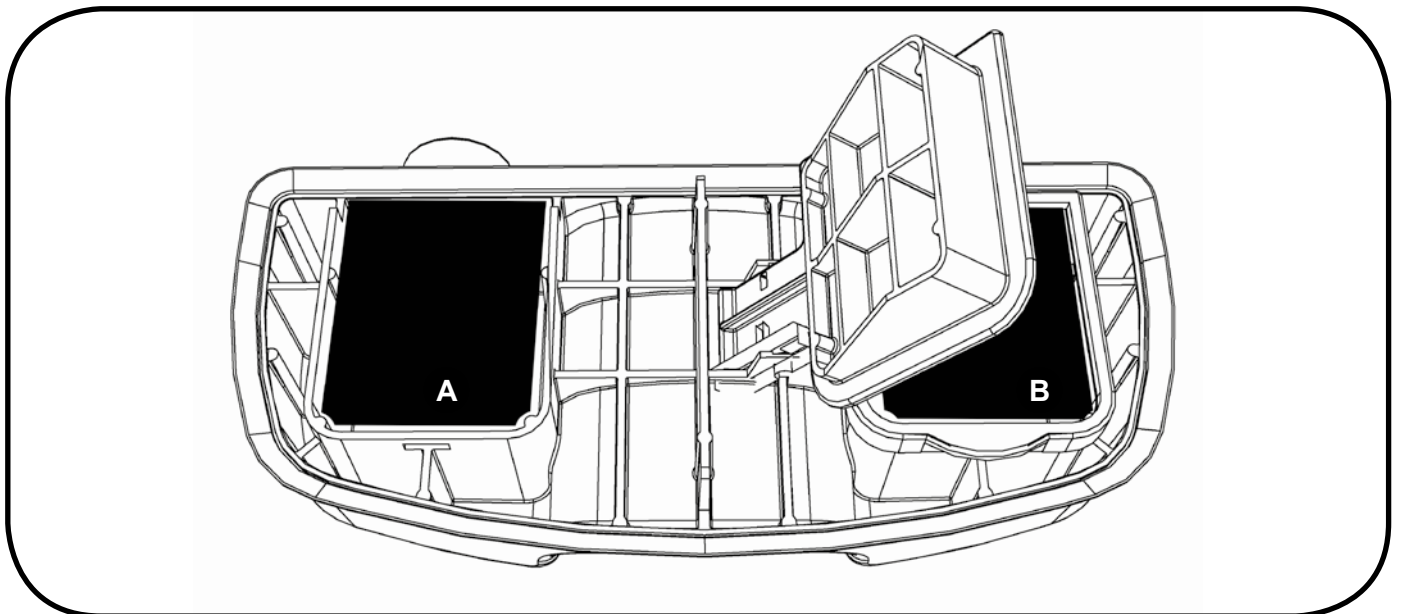
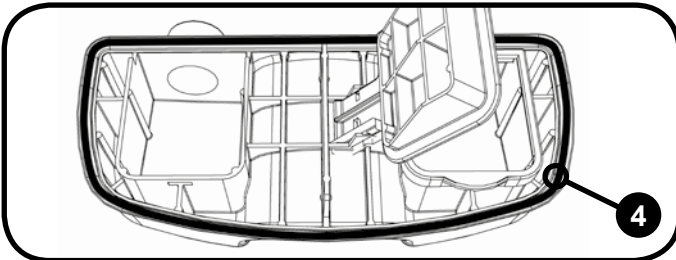
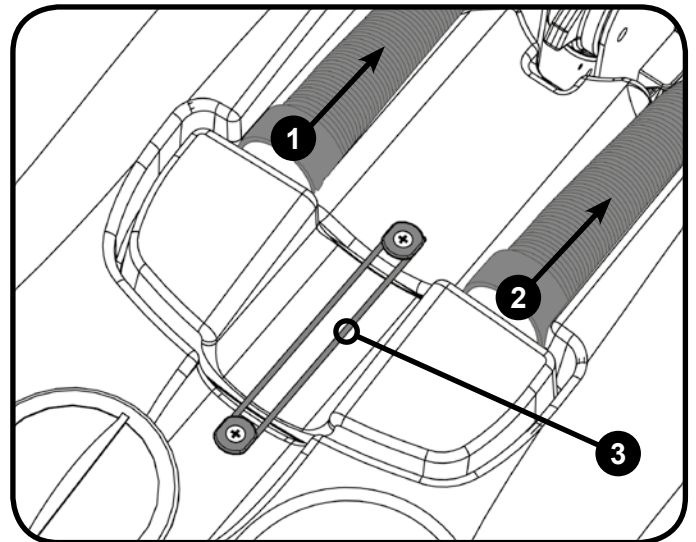

Remove the two filters clipped into the separator and flush with clean water (Fig.A & B). Replace by fitting the rear of the filter first then clipping the front to lock in place.

Changing the Floor Tool Blades



Always ensure that the machine is switched off prior to any maintenance.

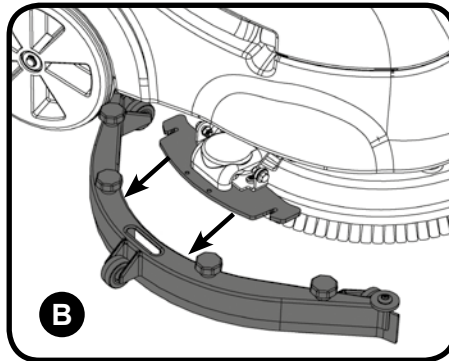
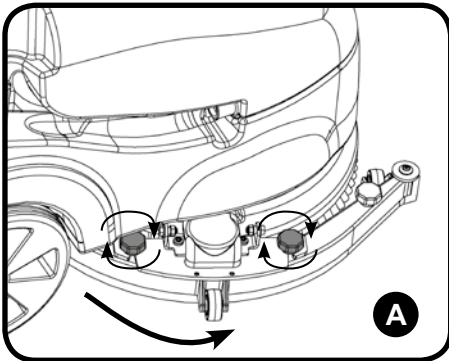

To change the floor-tool, firstly swing the floor-tool clear of the machine. Undo the two floor-tool retaining knobs (Fig.A).

Pull the floortool away from the machine (Fig.B).

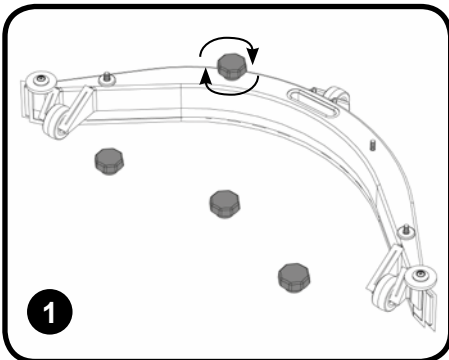

Unscrew the four knobs securing the blade holder (Fig.1).

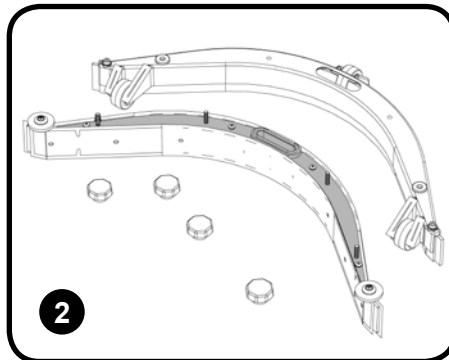

Remove the blade holder (Fig.2).

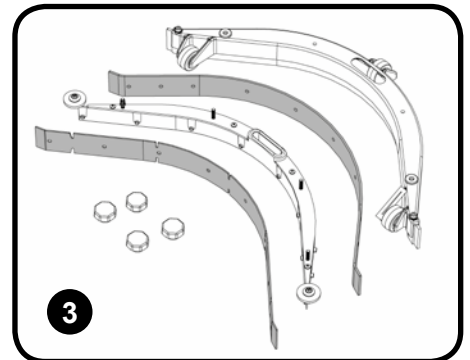

Replace the Squeegee blades using (903531) replacement blade set (Fig.3), fitting the blades on to the moulded location lugs.

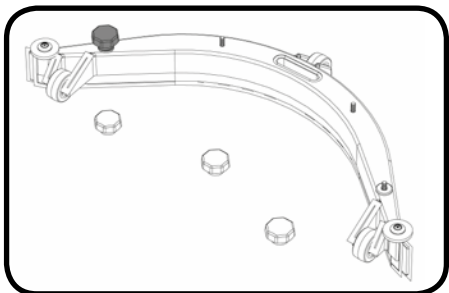

Refitting the Floor Tool Blades

Refit the blade holder, retain using the two outer knobs. Ensure the slotted blade goes to the front of the floor-tool.

Note: The blades are designed to be reversible, thus extending their useful working life. Refit the floor-tool using the two central knobs to the floor-tool.

Floor Tool Overview

1. Retaining knobs x 4
2. Front blade (slotted)
3. Blade carrier
4. Rear blade
5. Floor tool main body

NOTE: The blades are designed to be reversible, thus extending their useful working life.

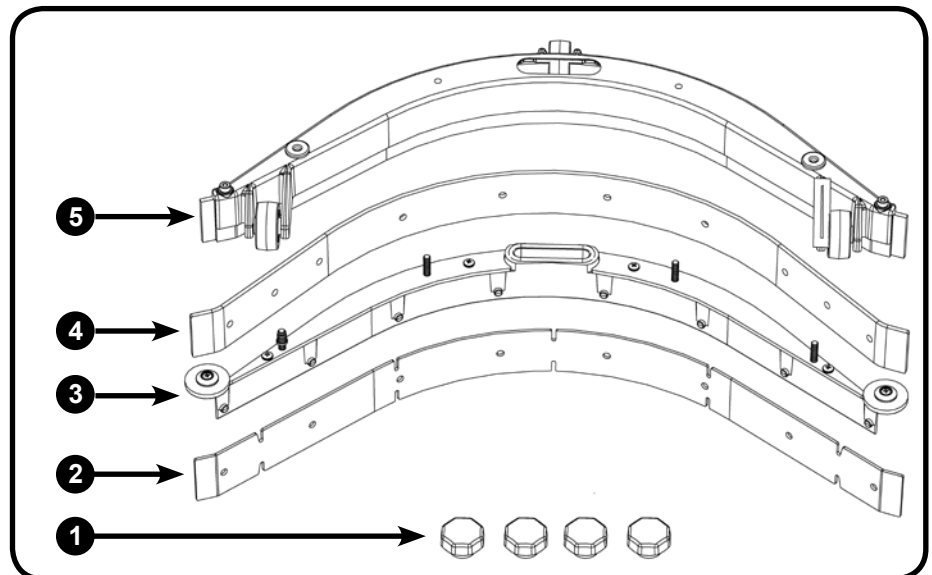

Regular Maintenance

Removing The Battery

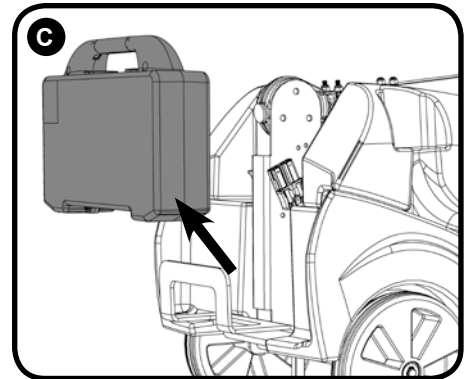
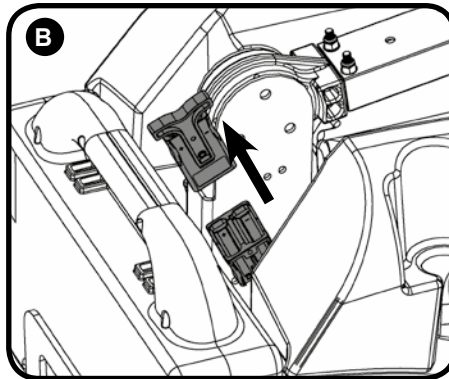
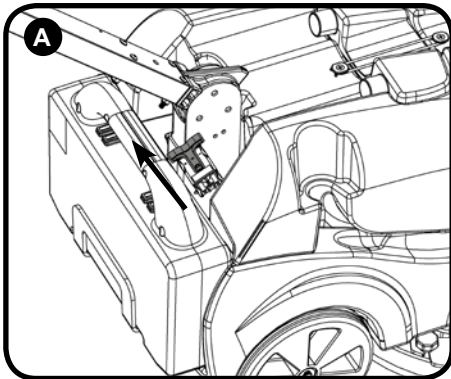

Unplug the battery from the machine using the red connection handle (Fig.A & B).

The battery can then be lifted from the machine for storage or charging (Fig.C).

Removing The Battery Pack Fuse

The battery pack comes fitted with a 40 amp safety fuse.

Replace the fuse using (208526) Numatic approved part

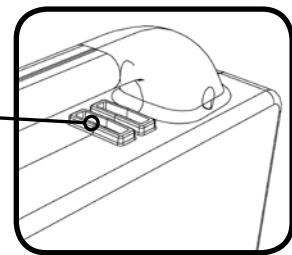
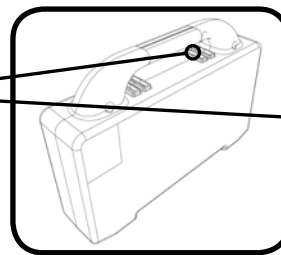

Battery Charging

Recharge the machine fully after its last use. Do not leave the machine in a discharged state. Under abnormal use; i.e. leaving the machine without charging for a period of time, we advise that you disconnect the battery from the machine. If the machine will be standing unused for a period of 30 days or more, then batteries must be fully charged.

Note: Batteries should be recharged every three months. Charge fully the day before you start using the machine again.

Under normal daily usage: Recharge batteries after each use regardless of machine operation time. Connect the charger unit to the battery and plug the charger into a suitable power supply.



Signal (LED)	Meaning
Red LED on	First phase (constant current mode)
Yellow LED on	Second phase (constant voltage mode)
Green LED on	Third phase (constant voltage mode) charge completed
Red LED flashing	Safety timer exceeded Internal short circuit
Yellow LED flashing	Battery not connected Output short circuit Unsuitable Battery

The battery charge level meter displays the charge level of the batteries; when fully charged, all meter lights are illuminated. As the machine is used and the batteries are discharged, the Battery charge level meter lights will go out from top to bottom. If the battery charge level is allowed to discharge to the point that only one red light remains illuminated, the operator should charge the battery.

The battery supplied for this machine allows for a run time of 45 mins approx (Hi Mode), when fully charged.

The battery pack must be fully discharged and recharged over a few cycles and brushes need to be worn in to achieve maximum efficiency.

Charge time for a fully discharged battery, is approximately 6 hours.

The HTB 1840 & TTB 1840 come with its own stand-alone charger.

Connect the charger to a suitable power supply.

Once mains power is connected the red charging indicator will illuminate. To ensure a full charge, the battery should be left for a period of 6 hrs. Once fully charged, disconnect the charger from the power supply and the charger lead from battery.

Note: Your charger will need resetting between subsequent battery charging, remove the charger from AC power supply to reset.

Face Fitting Instructions

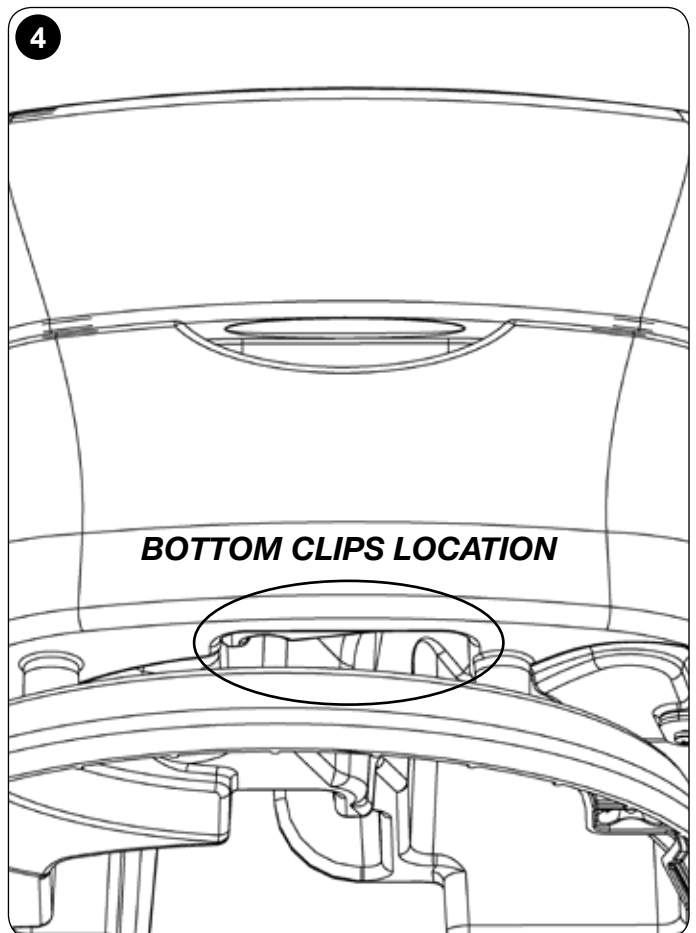
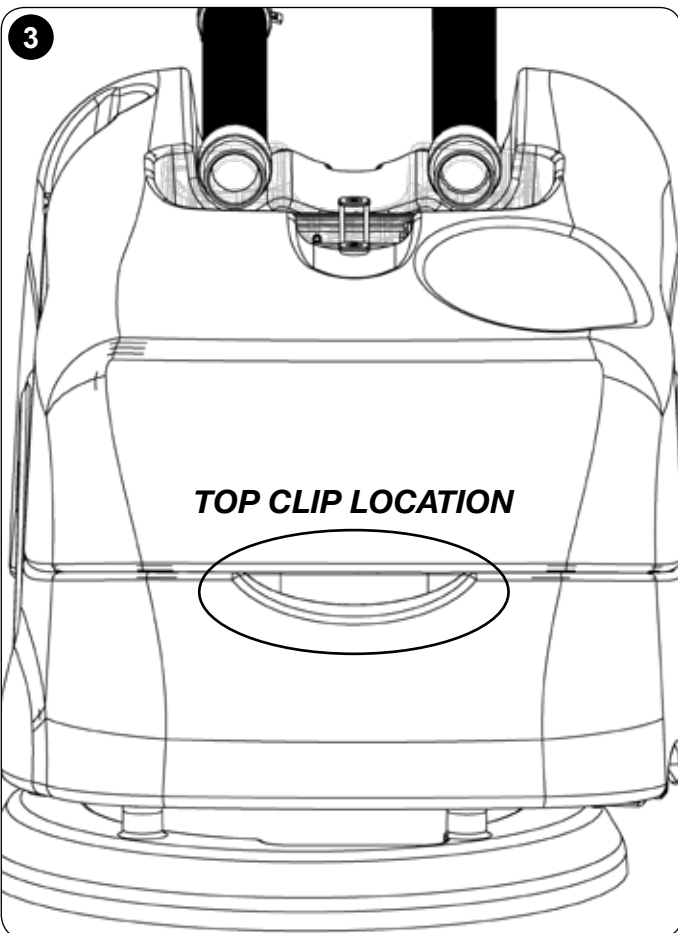
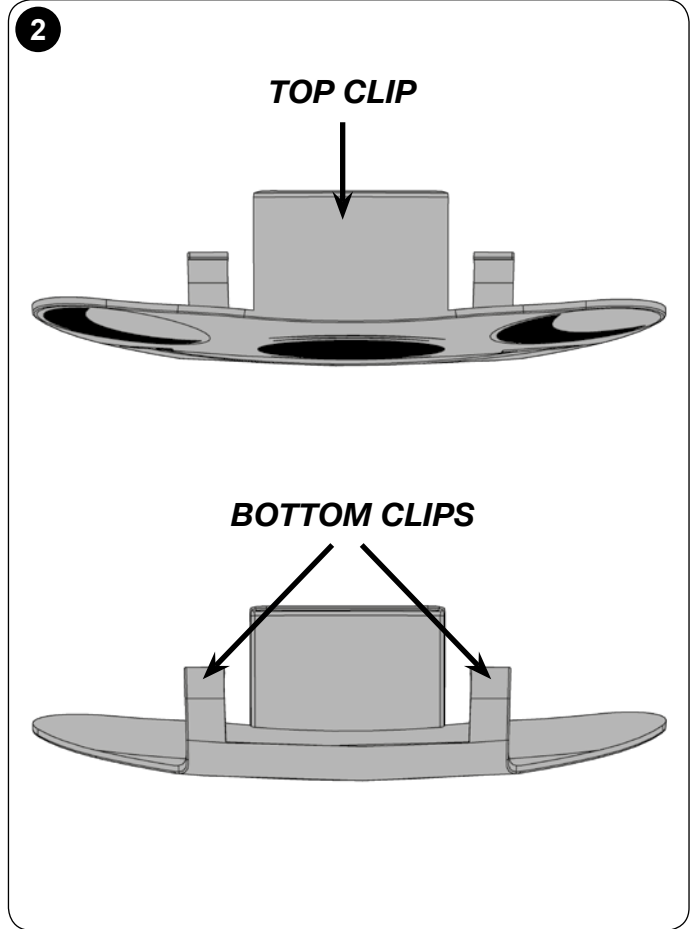
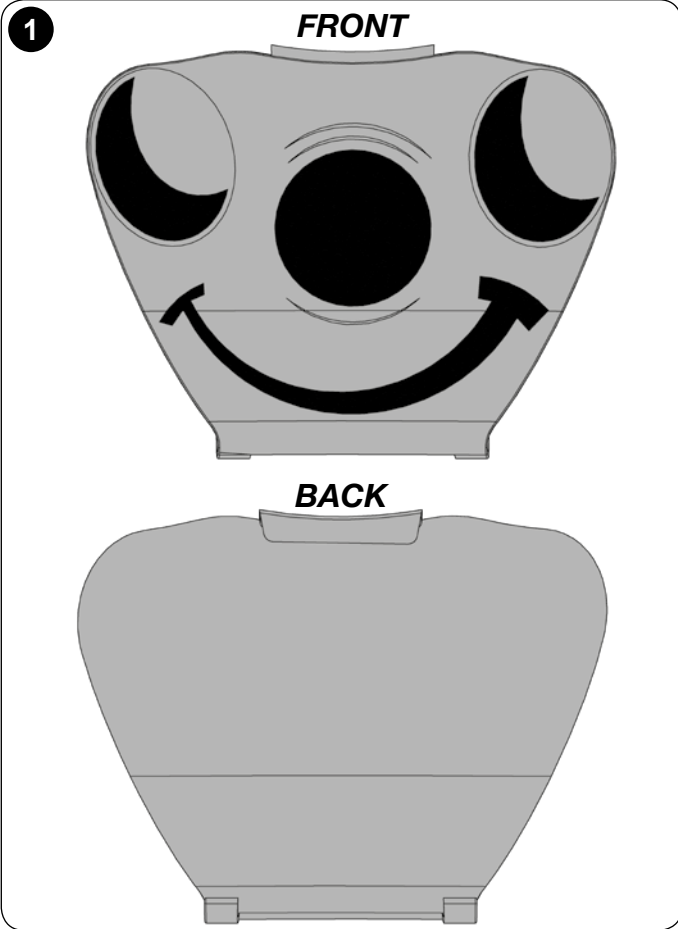

Face Fitting Instructions

5

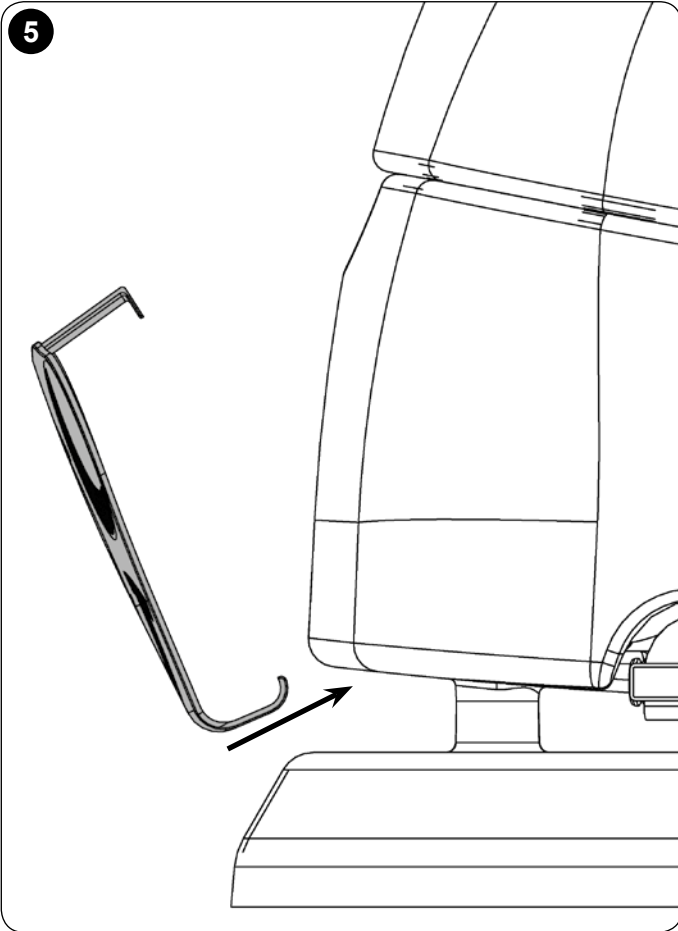

6

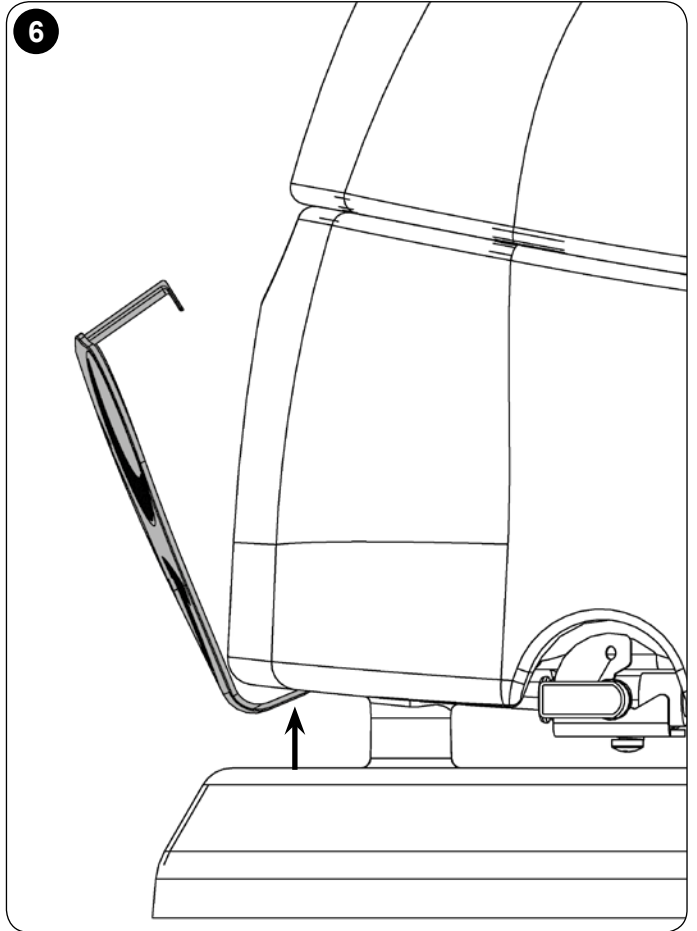

7

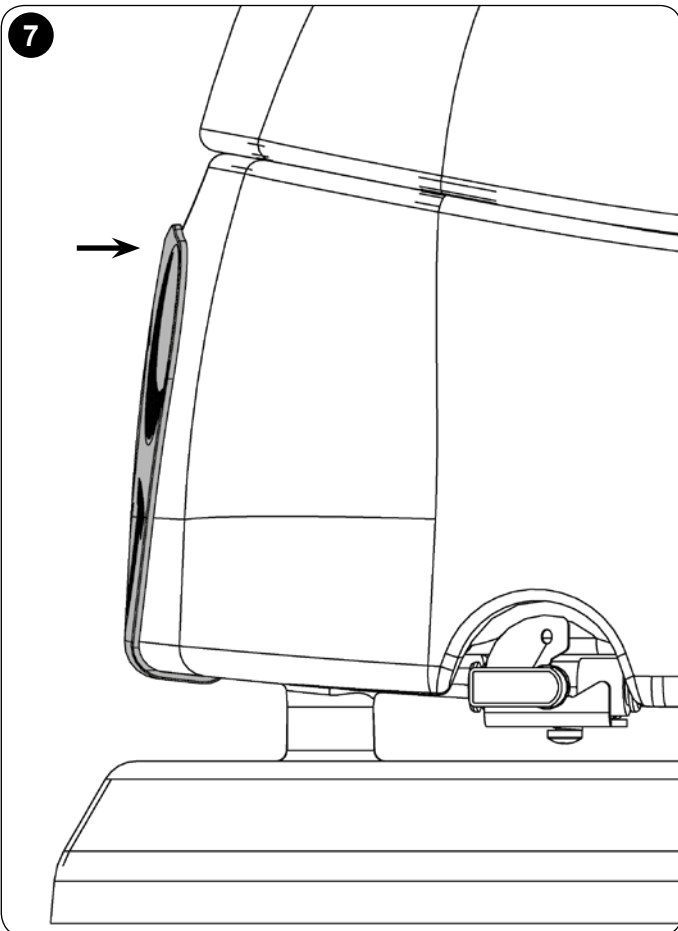

8

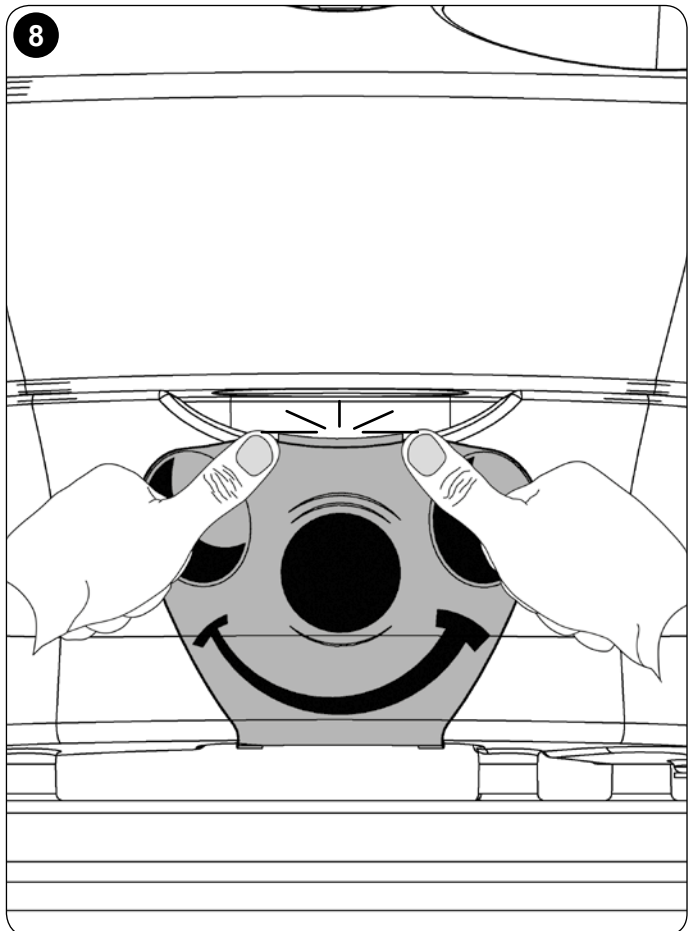

Specifications

Model - HTB 1840 & TTB 1840G					
Brush Motor	Vac Motor	Brush Sizes	Pad sizes	Net Weight	Gross Weight (Full)
400 W	24V 300 W	400 mm	360 mm	52 Kg	70 Kg
Protection Class	Run Time	Water Capacity	Fluid Flow	Noise	Cleaning Speed
IPX4	Hi - 35 mins Lo - 45 mins	18 L	0 - 0.35 L/Min	Hi - ≤ 70.3 dB(A) Lo - ≤ 68.2 dB(A)	0 - 4.2 KPH
Brush Speed	Brush Pressure	Pad Pressure	Dimensions	Hand Arm Vibration	Recharge Time
Hi - 150 Rpm Lo - 130 RPM	27.4 g/cm ²	26.2 g/cm ²	Width = 520 mm Length = 850 mm Height = 1132 mm	0.6 m/s ²	6 hrs

Trouble Shooting

PROBLEM	CAUSE	SOLUTION
Machine will not operate	Missing or blown fuses Battery not connected Low battery charge	Fit or replace fuse (page 11) Connect battery (page 4/11) Charge batteries (page 11)
Vacuum will not operate	Vacuum not turned on	Turn on vacuum (page 7)
Poor water pick-up	Waste-water tank full Clogged / blocked vacuum hose Loose hose connections Debris basket filter clogged / blocked Separator filter clogged / blocked Poor separator seal Damaged separator seal Damaged / split vacuum hose Damaged floor-tool blades Low battery charge	Empty waste-water tank (page 8/9) Remove and clean (page 9) Push tight connections (page 9) Remove and clean (page 9) Remove and clean (page 9) Clean and refit (page 9) Renew (contact service dept) Renew (contact service dept) Renew (contact service dept) Recharge batteries (page 11)
No brush / scrub function	No brushes fitted Brush overloaded	Check and fit (page 4/5) Reset machine (page 7)
Little or no water flow	Clean-water tank empty Incorrect water flow setting	Fill clean-water tank (page 6) Adjust tap as desired (page 5/7)
Machine just 'stops' while operating	To much load on the brush system Blown fuse in Battery pack	Reset the machine and decrease the brush load to best suit the floor type (page 7) Replace 40 Amp fuse (page 11)

Failure to rectify the problem or in the event of a breakdown contact your Numatic dealer or Numatic Technical helpline +44 (0)1460 269268

About the Machine

Rating Label	
1	Company Name & Address
2	Machine Description
3	Voltage Frequency
4	Power rating
5	WEEE Logo
6	Ingress Protection Rating
7	Max Gradient
8	CE Mark
9	Weight (ready to use)
10	Machine yr/wk Serial number
11	Machine Description
12	Noise Rating
13	Hand Arm Vibration

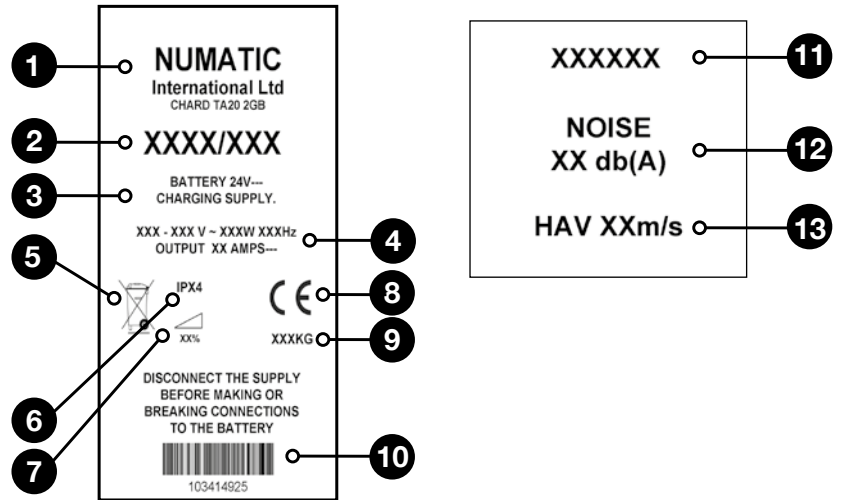

WEEE (Waste, Electrical and Electronic Equipment)

Scrubber dryer Accessories and packaging should be sorted for environmentally-friendly recycling. Only for EU countries.

Do not dispose of scrubber-dryer into household waste.

According to the European Directive 2002/96/EC on waste electrical electronic equipment and its incorporation into national law.

Scrubber-dryers that are no longer suitable for use must be separated, collected and sent for recovery in an environmentally-friendly manner.



PPE (Personal protective equipment) that may be required for certain operations.

Ear Protection	Safety Footwear	Head Protection	Safety Gloves	
Dust / Allergens Protection	Eye Protection	Protective Clothing	Hi-Vis Jacket	Caution Wet Floor Sign

NOTE: A risk assessment should be conducted to determine which PPE should be worn.

Safety Critical Component:

Charging Leads: H05VV-F x 1.0 mm² x 3 Core
Battery Charger: 220 / 240 Volt

***In the event of a breakdown contact
your Numatic dealer or the
Numatic Technical
help line +44 (0)1460 269268***



**ORIGINAL INSTRUCTIONS
READ MANUAL BEFORE USE**

Information for Scrubber Dryer

COMPONENT	INTERVAL	INSPECT FOR
Mains Lead	DAILY	Scuffing, cracks, splits, conductors showing
Brushes	DAILY	Bristle damage, wear, drive collar wear
Squeegee Blade	BEFORE EACH USE	Wear, cracks, splits
Filters	BEFORE EACH USE	Clogging and debris retention
Tanks	AFTER EACH USE	Rinse dirty water tank after use



WARNING

As with all electrical equipment care and attention must be exercised at all times during its use, in addition to ensuring that routine and preventative maintenance is carried out periodically in order to ensure its safe operation.

Failure to carry out maintenance as necessary, including the replacement of parts to the correct standard could render this equipment unsafe and the manufacturer can accept no responsibility or liability in this respect. When ordering spare parts always quote the Model Number / Serial Number specified on the Rating Plate. Warning do not use on slopes exceeding 2%.

This appliance is not intended for use by persons (including children) with reduced physical, sensory or mental capabilities, or lack of experience and knowledge, unless they have been given supervision or instruction concerning use of the appliance by a person responsible for their safety. Children should be supervised to ensure that they do not play with the appliance. When detergents or other liquids are used, read the manufacturer's instructions.

Only use brushes provided with the appliance or those specified in the instruction manual. The use of other brushes may impair safety. A full range of brushes and accessories are available for this product. Only use brushes or pads which are suitable for the correct operation of the machine for the specific task being performed.

It is essential that this equipment is correctly assembled and operated in accordance with current safety regulations. When using the equipment always ensure that all necessary precautions are taken to guarantee the safety of the operator and any other persons who may be affected. Wear nonslip footwear when scrubbing. Use a respiratory mask in dusty environments. The machine, while charging, must be positioned so that the mains plug is easily accessible. When cleaning, servicing or maintaining the machine, replacing parts or converting to another function the power source shall be switched off. Mains operated machines shall be disconnected by removing the power plug, and battery operated machines shall be disconnected by removing the fuse.

In order to prevent unauthorised use of the machine the power key must be removed after use. Machines left unattended shall be secured against unintentional movement. When detergents or other liquids are used, read the manufacturer's instructions.

Operators shall be adequately instructed as to the correct use of the machine.

If this product does not have a factory installed Numatic battery charger, then it is the responsibility of the owner and user of the product to ensure that the charging system and battery combination are compatible, fit for purpose and safe to use.



CAUTION

This machine is not suitable for picking-up hazardous dust. Do not use on surfaces having a gradient exceeding that marked on the appliance. The machine is not to be stored outdoors in wet conditions. This machine is for indoor use only. Read the instruction manual before using the appliance. This product meets the requirements of IEC 60335-2-72

NOTES: This machine is also suitable for commercial use, for example in hotels, schools, hospitals, factories, shops and offices for other than normal housekeeping purposes.



DO

- Ensure only competent persons unpack/assemble the machine.
- Keep your machine clean.
- Keep your brushes in good condition.
- Replace any worn or damaged parts immediately.
- Regularly examine the power cord for damage, such as cracking or ageing. If damage is found, replace the cord before further use.
- Only replace the power cord with the correct Numatic approved replacement parts.
- Ensure that the work area is clear of obstructions and / or people.
- Ensure that the working area is well illuminated.
- Pre-sweep the area to be cleaned.



DON'T

- Use steam cleaners or pressure washers to clean the machine or use in the rain.
- Attempt machine maintenance or cleaning unless the power plug has been removed from the supply outlet.
- Allow any inexperienced repairs. Call the experts.
- Strain cable or try to unplug by pulling on cable.
- Leave the brush pad on the machine when not in use.
- Allow the machine to be used by inexperienced or unauthorised operators or without appropriate training.
- Use the machine without the solution tanks properly positioned on the machine, as shown in the instructions.
- Expect the machine to provide trouble-free, reliable operation unless maintained correctly.
- Run the machine over power cable during operation.
- Lift or pull the machine by any of the operating triggers, use the main handle.
- Remove the handle from the machine except for service and repair.



**ORIGINAL INSTRUCTIONS
READ MANUAL BEFORE USE**

Information for Scrubber Dryer

Precautions when working with batteries

1. Always wear protective clothing e.g. face visor, gloves and overalls when working with batteries.
2. Whenever possible always use a properly designated and well-ventilated area for charging.
Do not smoke or bring naked flames into the charging area.
3. Remove any metallic items from hands, wrists and neck i.e. rings, chains etc. before working on a battery.
4. Never rest tools or metallic objects on top of the battery.
5. When charging is complete disconnect from the mains supply.
6. The batteries must be removed from the machine before it is scrapped.
7. The machine must be disconnected from the supply when removing the battery.
8. To remove the batteries:- Disconnect machine from the mains supply (if charging) and ensure batteries are switched off with circuit disconnect switch (see page 19). Disconnect hoses from separator and tanks.
Remove separator and tanks. Unscrew battery strap fixings and remove.
Undo battery terminals and remove. Remove batteries.
9. The batteries are to be disposed of safely and in accordance with the battery directive.
10. Only use genuine Numatic replacement batteries.
11. Do not allow the batteries to become fully discharged; it may not be possible to re-charge them.
Batteries should not be discharged below 9.5 volts with 10 amps flowing.
12. Do not allow one battery to be discharged separately to the other.
13. Do not mix batteries from different machines.
14. The batteries fitted to this product are Valve Regulated Lead Acid (VRLA) gel electrolyte type.
The fitting of any other type of battery may cause a safety hazard.

Battery Care

1. Battery Storage:

- a. Batteries must be stored in a dry, level and clean location not exceeding a temperature range of 5°C to 25°C.
- b. Batteries must be fully charged after 6 months when on-the-shelf and as a minimum every 3 months thereafter or if the battery voltage reduces to 12.6V.
- c. Batteries must be put into use within 12 months of the date of manufacture, failure to do so will lead to reduced capacity in the field.
(battery date code) - silver label on the battery - (e.g. 1649) = Year - 2016 / Week - 49.
- d. If a battery reaches 10.5V, irreversible damage has occurred. Under this condition, a battery should not enter into service and should be disposed of according to local authority guidelines.

2. During Use:

- a. Batteries must be recharged after every use regardless of machine run time
- b. If the machine is to be left dormant for any length of time complete the following:
 - i. Fully charge the batteries and remove the battery fuses
 - ii. Every 3 months insert the fuses and recharge
 - iii. Do not leave batteries dormant for more than 6 months

3. Warranty:

- a. Batteries are warranted for 600 cycles (2 Years) providing all battery care rules are followed
- b. To claim warranty the following details must be supplied
 - i. Serial number of the machine
 - ii. Battery date code (Show picture of battery date code)
 - iii. Date purchased
 - iv. Proof of Purchase
 - v. Maintenance history and charging regime

Daily

Keep the machine clean.

Ensure brushes/ pads/ squeegee/ filters are in good condition.

Check for any worn or damaged parts and replace immediately.

Drain and rinse dirty water tank after every use.

Store machine with brush deck secured in tilted position.

Weekly – as daily and –

Check brush or pad and skirt and rinse.

Check floor tool blades for wear and wipe clean.

Clean separator assembly including filter and check condition of seal.

Flush out system with clean water and clean filters.

Do not steam clean or pressure wash.

Batteries

Always re-charge the batteries after use.

Charge for a minimum of 4 hours after the green light has come on, this will prolong battery life.

**TwinTec
Maintenance**

Spare Parts

Part No.	SPARES & ACCESSORIES	Part No.	SPARES & ACCESSORIES
606260	BATTERY PACK (BOXED)	903531	SERILOR REPLACEMENT BLADE SET
606266	BATTERY & CHARGER PACK (UK)	903532	SERILOR COMPLETE SQUEEGEE ASSEMBLY
606267	BATTERY & CHARGER PACK (EURO)	303985	FILLER CAP ASSEMBLY
606268	BATTERY & CHARGER PACK (SWISS)	903544	FILLER CAP LID
606269	BATTERY & CHARGER PACK (USA)	237232	SEPERATOR FILTER
606270	BATTERY & CHARGER PACK (SOUTH AFRICA)	237260	GRIT BASKET
606271	BATTERY & CHARGER PACK (AUS)	231054	SUCTION HOSE
606272	CHARGER PACK (UK)	213055	VAC HOSE
606273	CHARGER PACK (EURO)	208471	CONSTANT TENSION CLIP
606274	CHARGER PACK (SWISS)	303997	DUMP-HOSE ASSEMBLY
606275	CHARGER PACK (USA)	208448	TANK DRAIN CAP
606276	CHARGER PACK (SOUTH AFRICA)	208526	REPLACEMENT 40AMP FUSE
606277	CHARGER PACK (AUS)	208455	M5 KNOB (BLACK)
		208537	CONSTANT TENSION CLIP (VAC HOSE)

Schematic Diagram

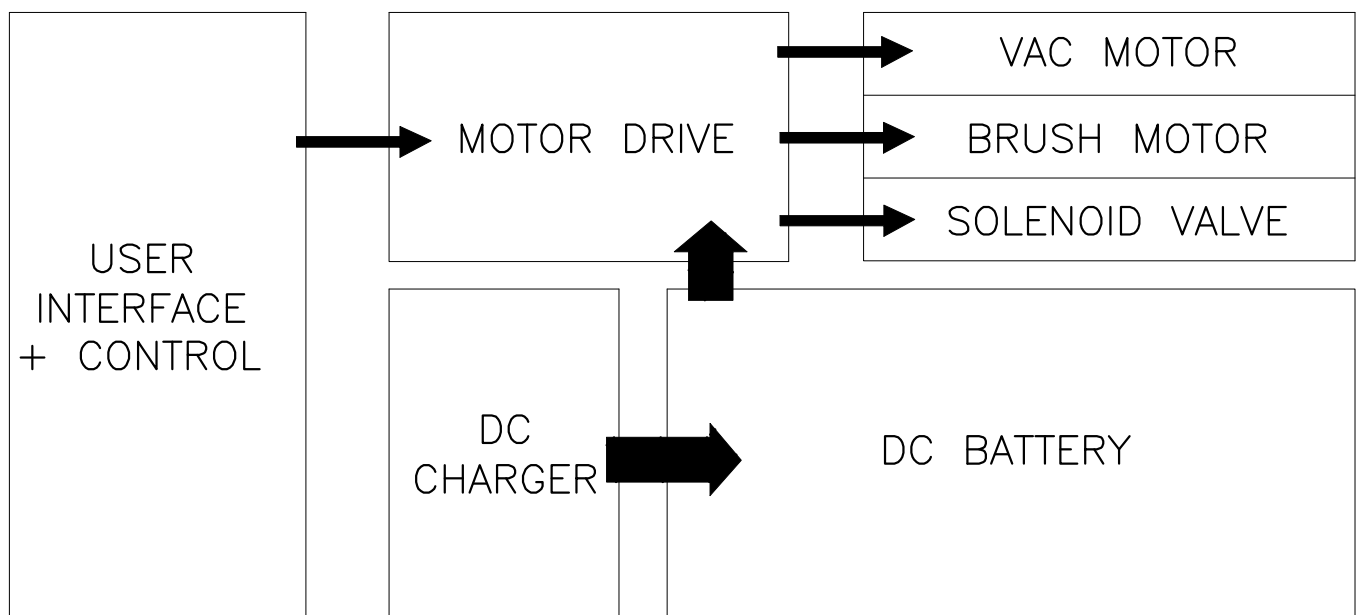

EU Declaration of Conformity



EU DECLARATION OF CONFORMITY

We hereby declare under our sole responsibility that the following equipment fulfils all the relevant provisions of the following EU Directives

Machinery Directive 2006/42/EC
EMC Directive 2014/30/EU
RoHS Directive 2011/65/EU

Machine Description: Scrubber Dryer
Machine Type: TTB1840, HTB1840 Series.

Relevant standards upon which conformity is declared include:

EN 60335-1: 2012 + A11:2014
EN 60335-2-72: 2012
EN 55014-1: 2006 + A1:2009 + A2:2011
EN 55014-2: 1997 + A1:2001 + A2:2008
EN 62233: 2008

A technical construction file for this equipment is retained at the manufacturer's address under the authorisation of the following signatory:

Name: Allyn Boyes Position: Development Manager

Signed  Date 3/10/17



Numatic International Ltd
Chard Somerset
TA20 2GB
www.numatic.co.uk

GB

Numatic International Warranty

Numatic International Limited warrant to the original purchaser that its products are free of defects in both material or workmanship for the period shown below:-

Homecare and Cleancare Vacuum cleaners.....	2 Years
Rotary Floor Machines.....	2 Years
Twintec Auto Scrubber Dryer.....	1 Year
Vario Ride-On Scrubber Dryer.....	1 Year / 1500 hours
Mopping, Compacts, Combi and Servocare Products.....	1 Year
Individual Accessories and Spare Parts.....	6 Months

Note: This warranty expressly excludes consumable parts such as carbon brushes, floor brushes, mops, batteries etc, that are considered replaceable from time to time during the normal working life of the machine.

- A. The warranty period commences from the date the goods are purchased.
- B. All warranty claims must be processed through the Dealer from whom the equipment was purchased. The Dealer will co-operate with the purchaser throughout the warranty claims procedure and will arrange any necessary repairs using genuine Numatic parts.
- C. If the original Dealer is no longer able to fulfil his obligations please contact Numatic International Limited with full details of the claim and proof of purchase so that this may be processed without delay.
- D. Any warranty claim can only relate to the specific part that is proven to be at fault and for which a replacement will be supplied but cannot be extended to constitute a claim against the complete machine.
- E. Numatic International will supply the Dealer with any warranty parts required, subject to the claim being validated, after return of the faulty items in accordance with Numatic International Limited's General Conditions of Sale.
- F. Claims will not be accepted if they are the result of fair wear and tear, misuse or abuse of any kind.
- G. No replacement will be given unless the appropriate evidence of the validity of the claim has been provided to the satisfaction of Numatic International Limited.
- H. Numatic International Limited reserve the right to charge for any unnecessary work carried out as a result of an invalid claim.
- I. No variation to this warranty may be made or implied by any member of Numatic International Limited or its Dealers unless such variation is in writing and authorised by the Company



Numatic International Limited. Chard, Somerset, TA20 2GB
Telephone: 01460 68600 Fax: 01460 68458

© Numatic International Limited

**This Machine Has Been Packed
With The Following**

- | | |
|------------------------------|--------------------------|
| Brush / Pad | <input type="checkbox"/> |
| Floor Tool | <input type="checkbox"/> |
| NuTab | <input type="checkbox"/> |
| Charging Lead & Battery Pack | <input type="checkbox"/> |
| Fuse Pack | <input type="checkbox"/> |

Signed

Distributed by:

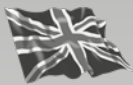

Numatic International Limited.
Chard, Somerset TA20 2GB ENGLAND
Tel.: 01460 68600 www.numatic.co.uk

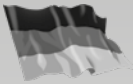

Numatic International GmbH. Fränkische Straße 15–19
D-30455 Hannover, DEUTSCHLAND
Tel.: 05 11 98 42 16 0 www.numatic.de

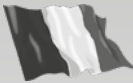

Numatic International SAS. 13 / 17 rue du Valengelier
77500 CHELLES, FRANCE
Tel: 01 64 72 61 61 www.numatic.fr



BeNeLux Distribution, Numatic International BV
Postbus 101, 2400 AC Alphen aan den Rijn, NEDERLAND
Tel: 0172 467 999 www.numatic.nl

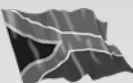

Numatic International (Pty.) Ltd.
16th & Pharmaceutical Roads, Midrand, Gauteng, SOUTH AFRICA 1685
Tel: 0861 686 284 www.numatic.co.za



Numatic International Schweiz AG.
Sihlbruggstrasse 142, 6340 Baar. SCHWEIZ
Tel: 0041 (0) 41 76 80 76 - 0 www.numatic.ch

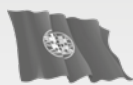

Numatic International ULDA. Rua da Boa Viagem, n.º 177
4470-600 Moreira, Maia PORTUGAL
Tel: +351 220 047 700 www.numatic.pt

This Product has been comprehensively inspected and checked during every stage of its manufacture.
including an in-depth electrical safety and functionality test.

Specification subject to change without prior notice
www.numatic.co.uk © Numatic International Limited

233968 08/18 (A33)